

DLK22KV

elettromagnetico valve



Zator
gluing solutions

DATASHEET





TECHNICAL DESCRIPTION

The electromagnetic valve DLK22KV has been designed and realized for its use on various kind of production machines operating at high speed: its design and versatility make it ideal for any applications that require the use of dispensing valves.

It's an high-speed dispenser of low and medium viscosity glues, adhesives and fluids (max 2500 mPas). It can be dispense glue dots. It is controlled by a Zator's microprocessor control or by an instrument of external control after testing and approval of Zator company.

Full stainless steel valve, zero cavity short nozzle (KV), needle with ceramic ball. The micrometric adjustment allows a fine control of dot size.

APPLICATION FIELDS

- packaging
- paper converting
- case maker
- printing machine
- tobacco industry
- assembly
- food industry

FLUID TYPES

- cold adhesives and glues
- inks
- paints
- low viscosity fluids

TECHNICAL DATA

technical data

Available nozzle diameters	from 0,3 to 1,5 mm
Valve body	stainless steel
Maximum fluid viscosity	~ 2500 mPas
Maximum working pressure	25 bar
Maximum working frequency	350 dots/sec.
Coil	6 or 24 Volt
Weight	320 g

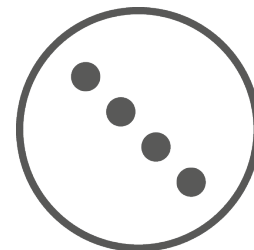

Dots



MODELS

code	description
B2755XX00	Electromagnetic valve DLK22KV 24 Volt
B2760XX00	Electromagnetic valve DLK22KV 6 Volt

*Replace XX value with nozzle diameter desired
Available nozzle diameters from 0,3 to 1,5 mm*

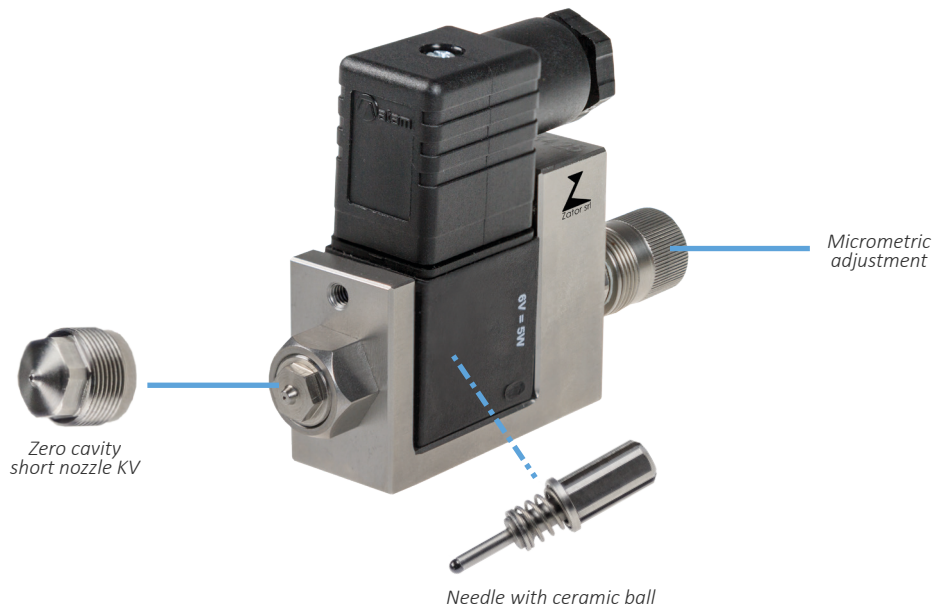



DIMENSIONS

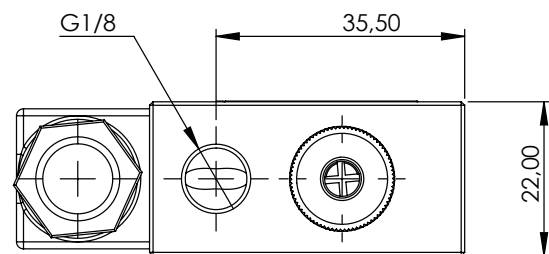
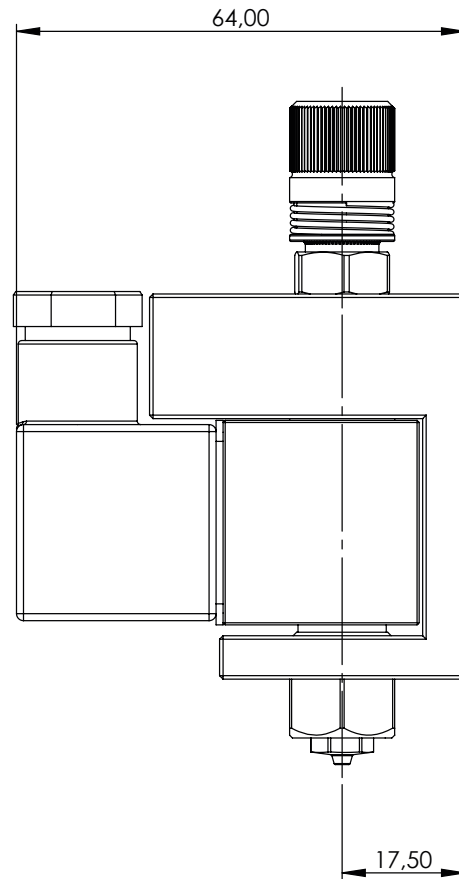
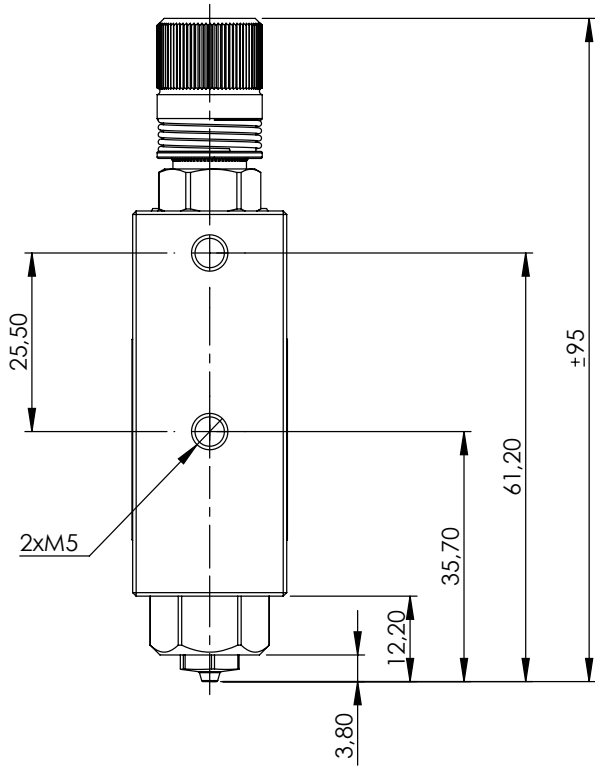



PARTS LIST

pos.	code	q.ty	description
1	B27000023	1	Micrometric adjustment
2	K92010401	1	O-ring
3	B27000016	1	Gun body
4	K92010901	1	O-ring
5	B27000052 B27000056 B27000053	1	Coil 6 Volt Coil 12 Volt Coil 24 Volt
6	CNN000027	1	Connector complete
7	GSK000020	1	Gasket
8	CNN000028	1	Connector
9	SC81030302	1	Screw
10	B27001300	1	Armature housing
11	B27003200	1	Needle KV
12	B27003500	1	Spring kit
13	H852101XX	1	Nozzle KV
			<i>Replace XX value with nozzle diameter desired Available nozzle diameters from 0,3 to 1,5 mm</i>
	KGN000014	1	Gasket kit



ELECTROMAGNETIC VALVE DLK22KV

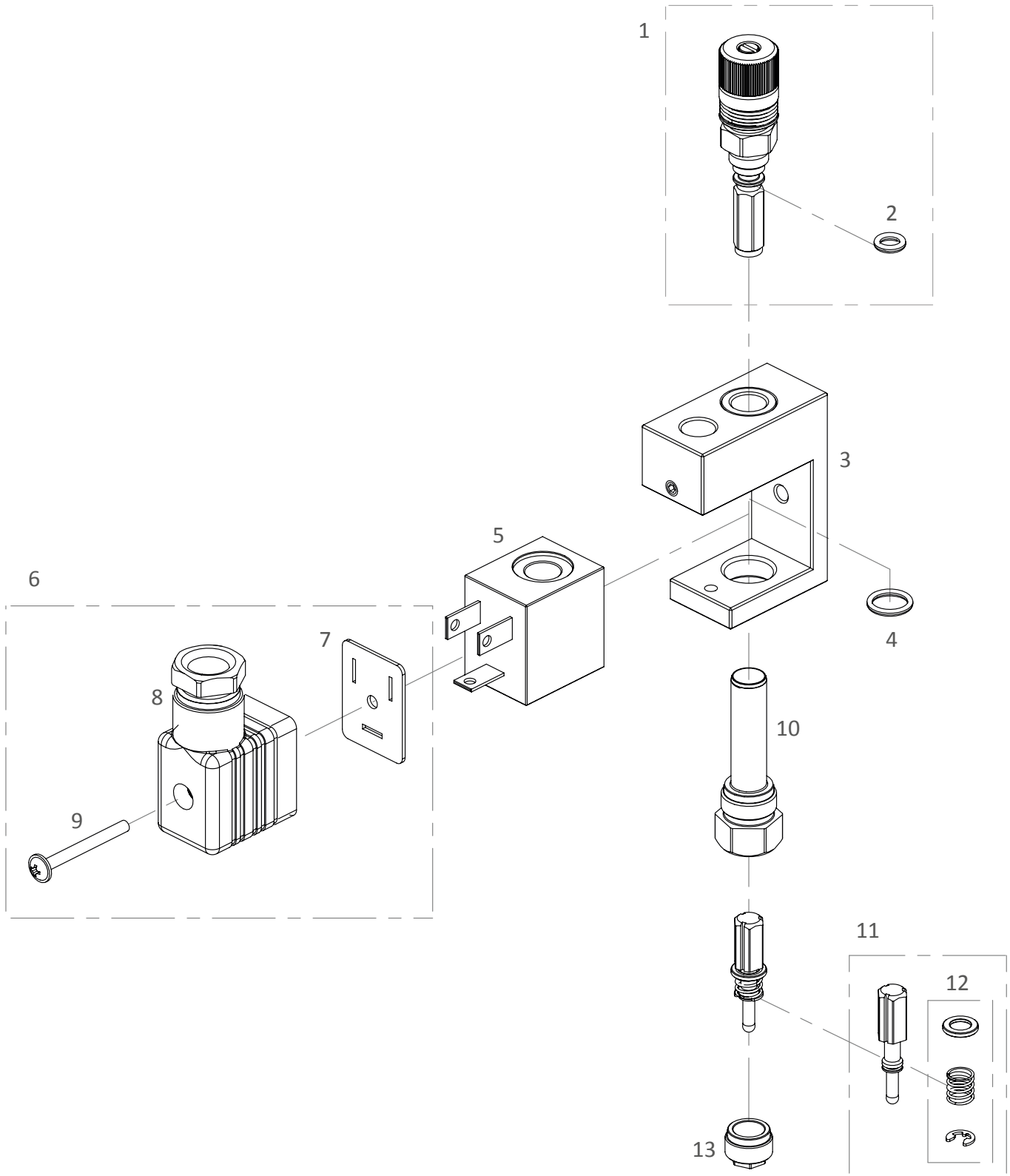

The images in this document are considered for illustration only. The company reserves the right for any changes without notice. Names, trademarks and logos are property of the author.

ZATOR SRL

Via Galvani, 11
20095 Cusano Milanino (MI)
Italy

Tel. +39 02 66403235

Fax +39 02 66403215

info@zator.it

www.zator.it



Datasheet
DLK22KV_v02

OCTOBER 2020

