

# DLK22LV

electromagnetic valve

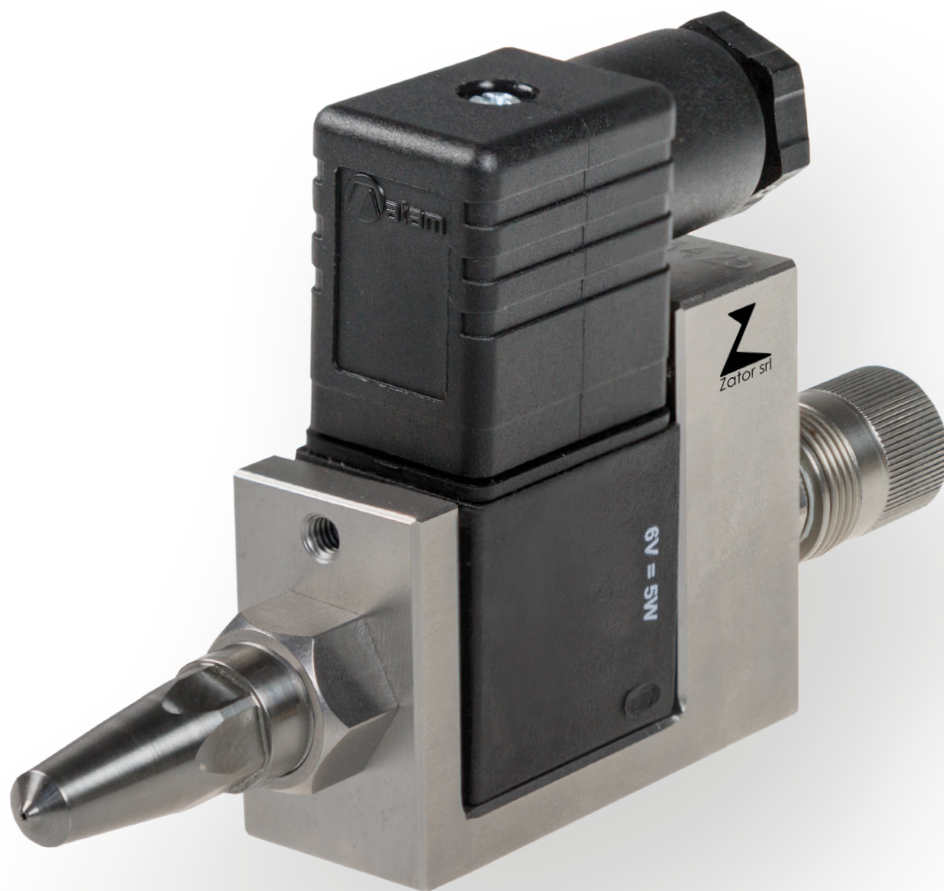

Zator  
gluing solutions

DATASHEET





## TECHNICAL DESCRIPTION

The electromagnetic valve DLK22LV has been designed and realized for its use on various kind of production machines operating at high speed: its design and versatility make it ideal for any applications that require the use of dispensing valves.

It's an high-speed dispenser of low and medium viscosity glues, adhesives and fluids (max 2500 mPas). It can be dispense glue dots or glue lines. It is controlled by a Zator's microprocessor control or by an instrument of external control after testing and approval of Zator company.

Full stainless steel valve, zero cavity long nozzle (LV), needle with ceramic ball. The micrometric adjustment allows a fine control of dot and line size.

### APPLICATION FIELDS

- packaging
- paper converting
- case maker
- printing machine
- tobacco industry
- assembly
- food industry

### FLUID TYPES

- cold adhesives and glues
- inks
- paints
- low viscosity fluids

## TECHNICAL DATA

### technical data

Available nozzle diameters	from 0,3 to 1,5 mm
Valve body	stainless steel
Maximum fluid viscosity	~ 2500 mPas
Maximum working pressure	25 bar
Maximum working frequency	350 dots/sec.
Coil	6, 12 or 24 Volt
Weight	330 g



*Dots and lines*



# MODELS

code	description
B2765XX00	Electromagnetic valve DLK22LV 24 Volt
B2780XX00	Electromagnetic valve DLK22LV 12 Volt
B2770XX00	Electromagnetic valve DLK22LV 6 Volt

*Replace XX value with nozzle diameter desired  
Available nozzle diameters from 0,3 to 1,5 mm*

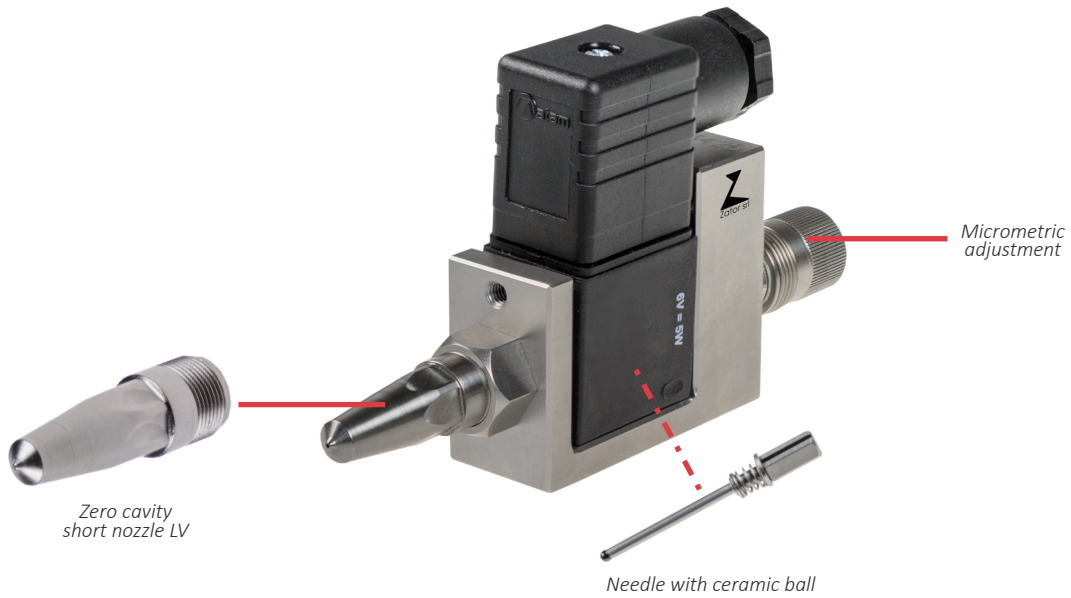



# PARTS LIST

pos.	code	q.ty	description
1	B27000023	1	Micrometric adjustment
2	RNG000008E	1	O-ring <sup>1</sup>
3	B27000016	1	Gun body
4	RNG000012E	1	O-ring <sup>1</sup>
5	B27000052 B27000056 B27000053	1	Coil 6 Volt Coil 12 Volt Coil 24 Volt
6	CNN210F00	1	Connector complete
7	GSK000020	1	Gasket
8	CNN210F01	1	Coil connector
9	SC81030302	1	Screw
10	B27001300	1	Armature housing
11	B27003300	1	Needle LV
12	B27003500	1	Spring kit
13	NZLE0102XXX	1	Nozzle LV
			<i>Replace XXX value with nozzle diameter desired Available nozzle diameters from 0,30 to 1,50 mm</i>
	KGN000014	1	Gasket kit <sup>1</sup>



ELECTROMAGNETIC VALVE DLK22LV

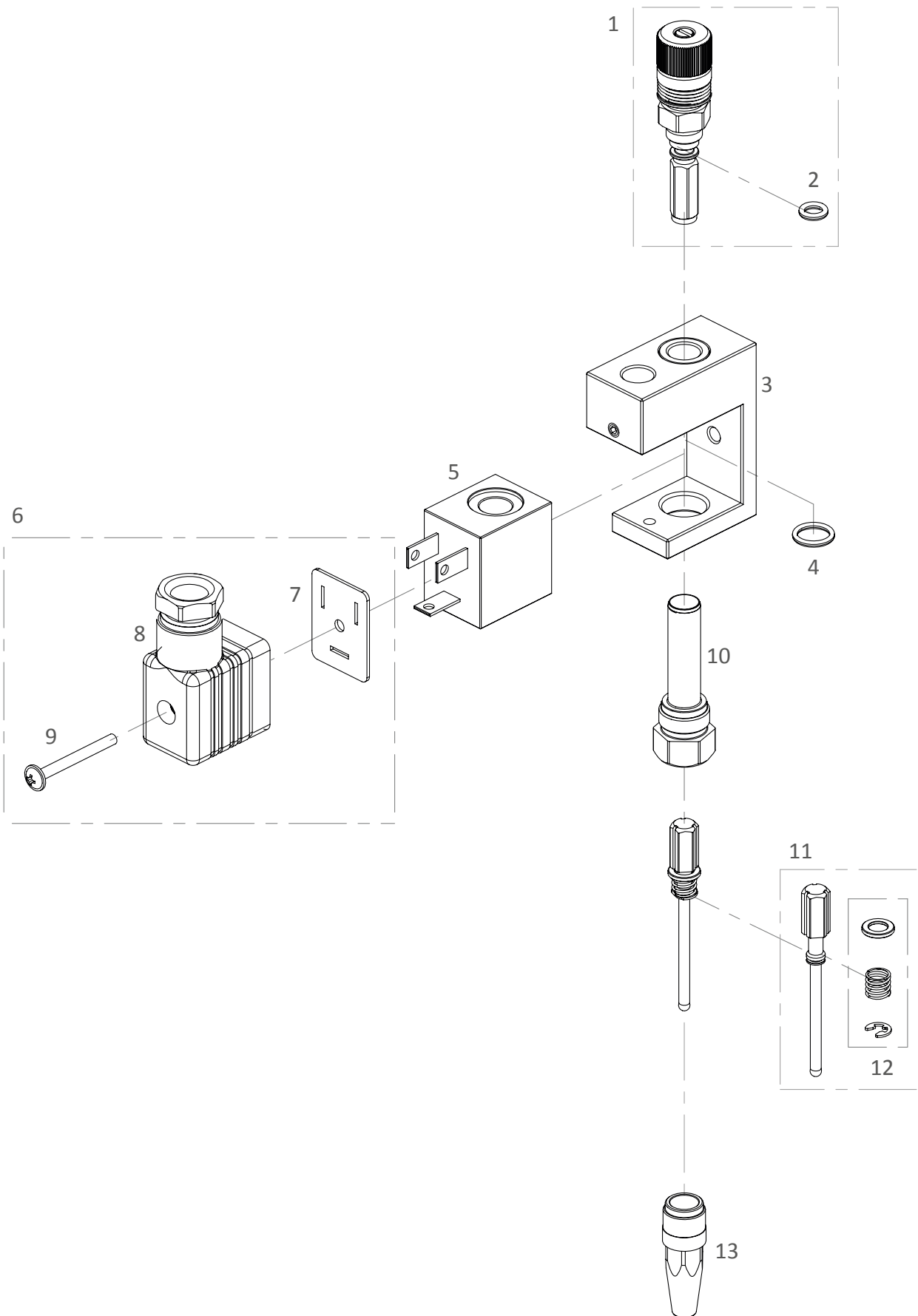

The images in this document are considered for illustration only. The company reserves the right for any changes without notice. Names, trademarks and logos are property of the author.



# DIMENSIONS

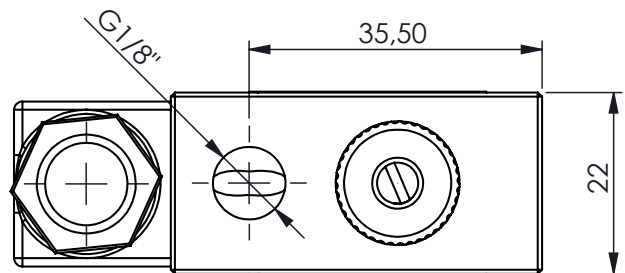
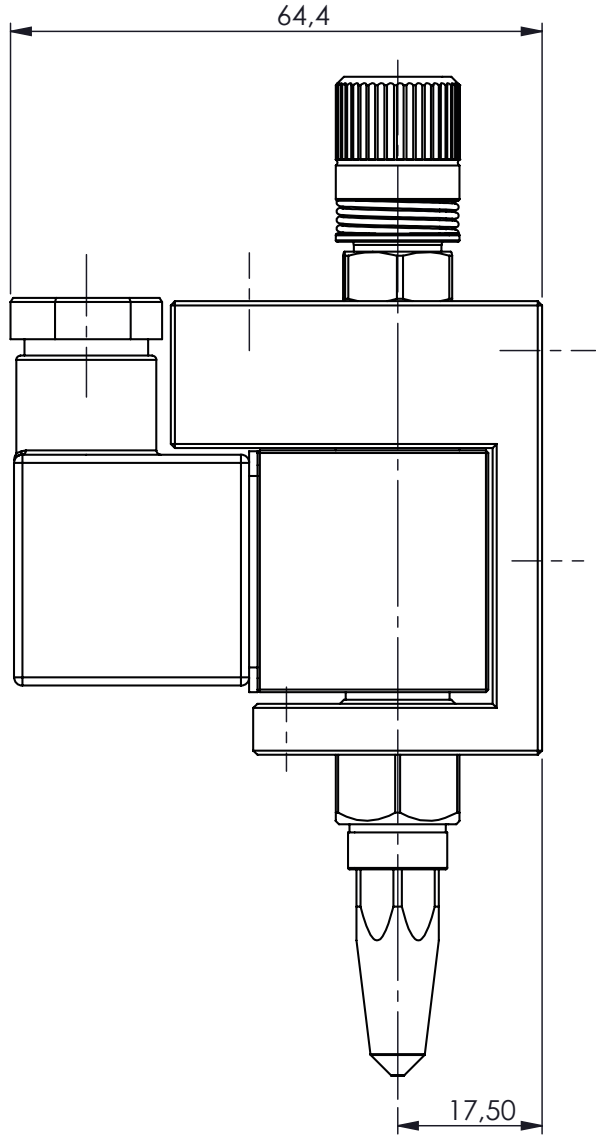
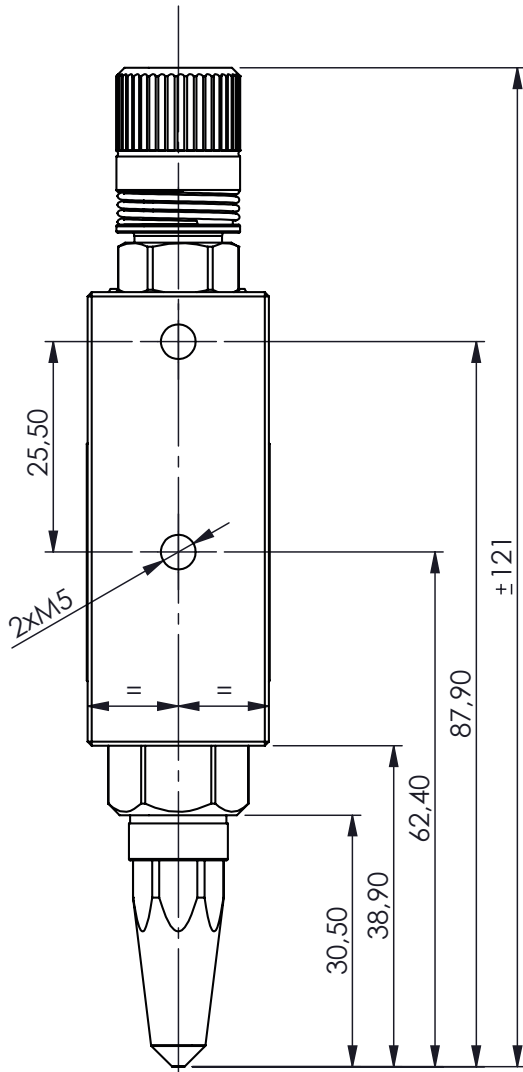

## ZATOR SRL

Via Galvani, 11  
20095 Cusano Milanino (MI)  
Italy

Tel. +39 02 66403235

Fax +39 02 66403215

[info@zator.it](mailto:info@zator.it)

[www.zator.it](http://www.zator.it)



Datasheet  
DLK22LV\_v03

MARCH 2023

