



**Zator**  
GLUING AND FLUID SOLUTIONS



DATASHEET

# MMF1

PNEUMATIC SPRAY VALVES

**ZATOR s.r.l.**

- Via Galvani, 11 - 20095 Cusano Milanino (MI) - ITALIA
- 0039 02 66403235
- [info@zator.it](mailto:info@zator.it)
- [www.zator.it](http://www.zator.it)



## TECHNICAL DESCRIPTION

The MMF1 pneumatic spray valve is designed and manufactured to be used on different types of machines: its design and versatility make it suitable for any application requiring the use of micro-spray valves. It is a dispenser of glues, adhesives and low-viscosity fluids. It is pneumatically controlled by two external solenoid valves, one to operate the valve and one to atomise the fluid. Robust and very small in size, it has a stainless steel zero-cavity nozzle, a non-stick coated cap and a self-cleaning needle that guarantee long operation. The micrometric adjustment allows the quantity of product dispensed to be regulated with extreme precision.

### APPLICATION FIELDS

packaging

paper converting

case maker

wood industry

assembly

food industry

### FLUID TYPES

adhesives and glues

inks

paint

lubricants

low viscosity fluid

### APPLICATION TYPES

spray

## TECHNICAL DATA

Available nozzle diameters	from 0,3 to 1,5 mm
Air pressure control	min. 5 bar
Drive type	single action
Maximum working pressure	6 bar
Nebulization pressure	from 0,5 to 2,5 bar
Weight	300 g



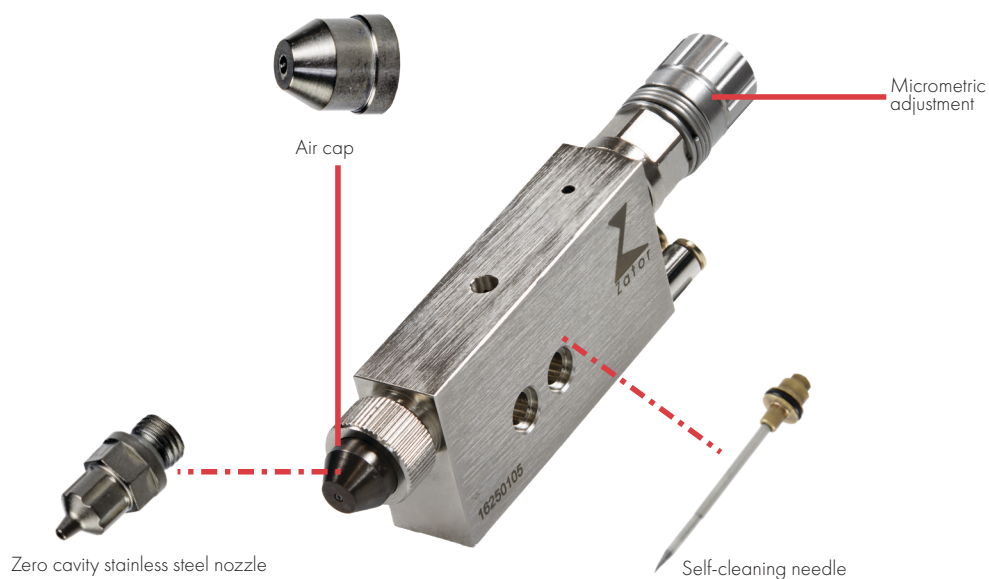

FULL STAINLESS STEEL  
VALVE AVAILABLE  
ON REQUEST

## CODE

MM03C01XX0

Spray valve MMF1 XX  
round cap

Substitute the desired nozzle diameter for the value XX  
Nozzle diameters available from 0,3 - 0,5 - 0,8 - 1,0 - 1,5 mm



## PARTS LIST PNEUMATIC SPRAY VALVES

pos.	code	q.ty	description
1	MCR000022	1	Micrometric adjustment complete
2	CCS000400	1	Spring
3	NDL1000XX	1	Needle complete
<small>Substitute the desired needle diameter for the value XX Needle diameters available 0,3 - 0,5 - 0,8 - 1,0 - 1,5 mm</small>			
4	RNG000011E*	1	O-ring
5	RNG000006E*	1	O-ring
6	H83100104	1	Lock bush
7	RNG000010E*	1	O-ring
8	RNG000008E*	1	O-ring
9	SHS30790T*	1	Gasket
10	BG000250	1	Valve body
11	FXC003001	1	Valve support
12	SC20030101	2	Screw
13	MMZF012XX	1	Nozzle spray
<small>Substitute the desired nozzle diameter for the value XX Nozzle diameters available 0,3 - 0,5 - 0,8 - 1,0 - 1,5 mm</small>			
14	MMZF01105	1	Air cap 0,3 - 0,5 mm
	MMZF01108	1	Air cap 0,8 - 1,0 mm
	MMZF01115	1	Air cap 1,5 mm
15	MMZF01310	1	Ghiera
16	RRAZ0249	2	Fitting
*	KGN0003002		Gasket kit

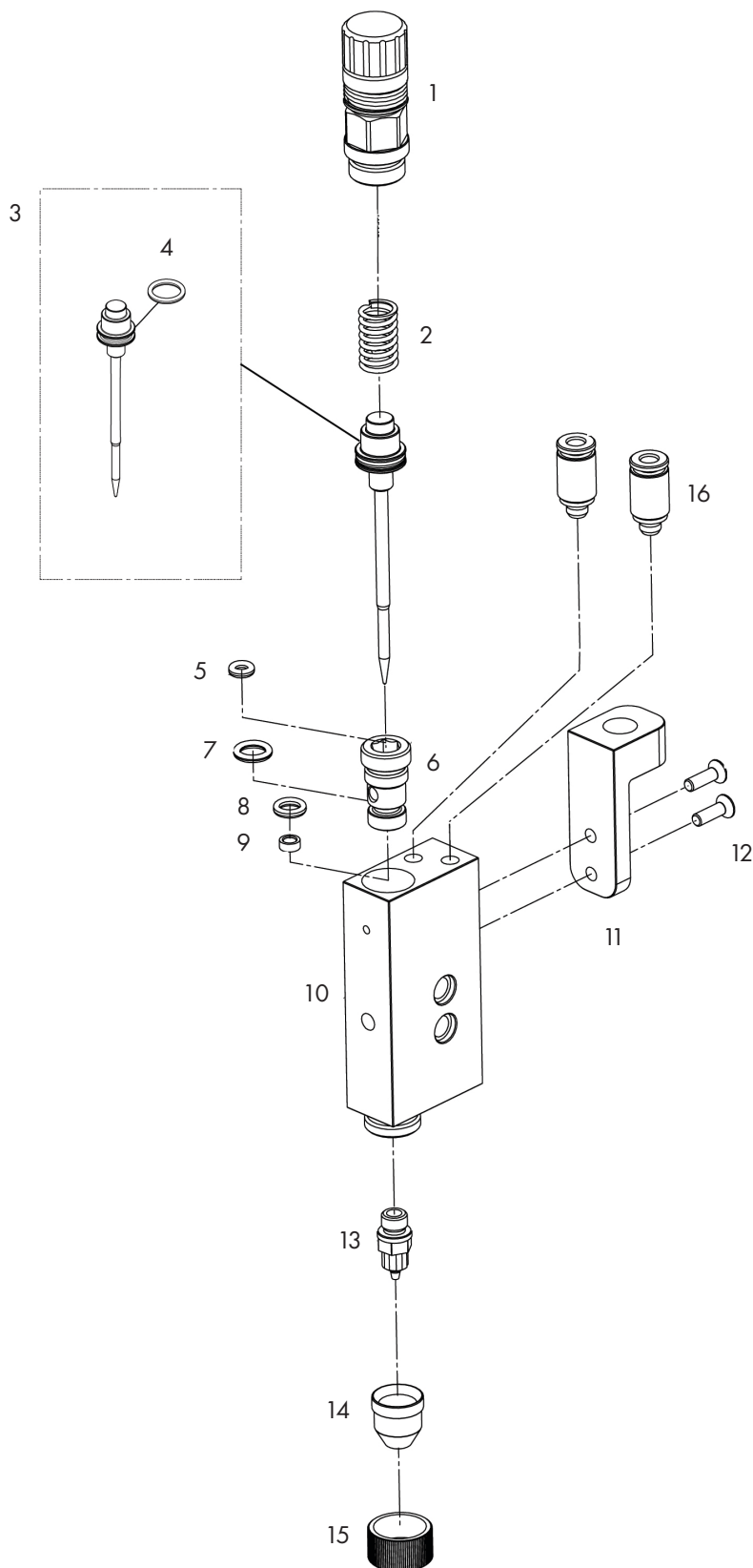

The images in this document are considered for illustration only. The company reserves the right for any changes without notice. Names, trademarks and logos are property of the author. All dimension are in millimetres.



# DIMENSIONS

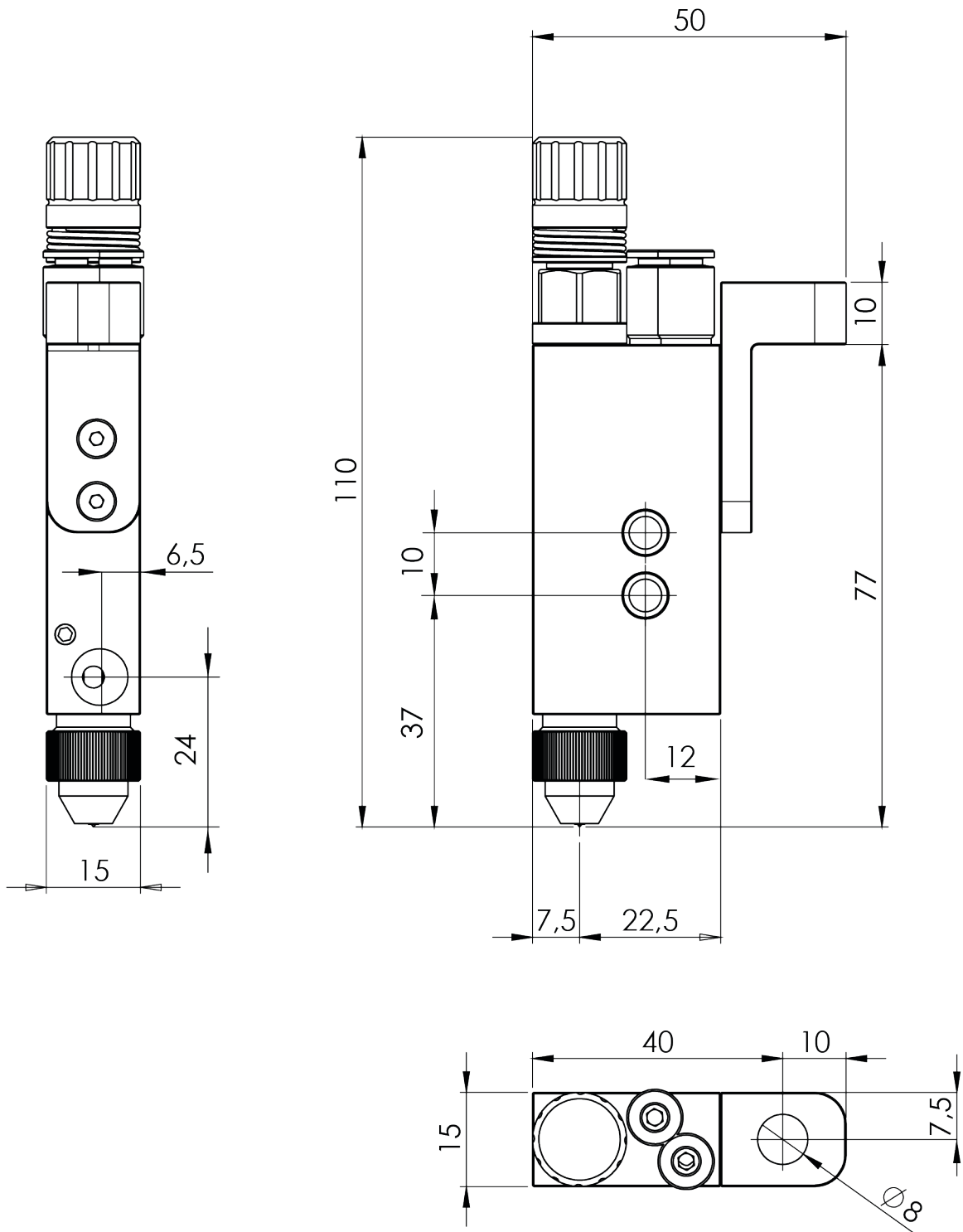



**Zator**  
GLUING AND FLUID SOLUTIONS

DATASHEET MMF1\_V01

**ZATOR SRL**

Via Galvani, 11  
20095 Cusano Milanino (MI)  
Italia

Tel. +39 02 66403235

Fax +39 02 66403215

[info@zator.it](mailto:info@zator.it)

[www.zator.it](http://www.zator.it)

