



Zator
GLUING AND FLUID SOLUTIONS



DATASHEET

VH2 SPL 30

ELECTROMAGNETIC COATING VALVE

ZATOR s.r.l.

- Via Galvani, 11 - 20095 Cusano Milanino (MI) - ITALY
- 0039 02 66403235
- info@zator.it
- www.zator.it



TECHNICAL DESCRIPTION

The VH2 SPL 30 is a 30 mm electromagnetic coating valve designed for applications requiring the coating of short beads. Derived from the VH2 model, it ensures rapid response times and high-frequency dispensing cycles, making it ideal for high-productivity automated lines. Manufactured entirely in stainless steel, it can be easily integrated even in confined spaces.

It is equipped with:

- Coating head with 30 mm lips, with a useful coating width of 25 mm
- Micrometric adjustment to precisely set the quantity of product dispensed
- Coils available in 6 or 24 Volts, to guarantee integration flexibility
- Fully electromagnetic actuation, which eliminates the need for compressed air, ensuring high cycles and dosing repeatability

APPLICATION FIELDS

packaging

paper industry

assembly

food

FLUID TYPES

cold adhesives and glues

low viscosity fluids

APPLICATION TYPES

coating

TECHNICAL DATA

Max coating widths	25 mm
Coating head widths	30 mm
Max fluid pressure	35 bar
Coil	6 or 24 Volt
Weight	400 g



Coating

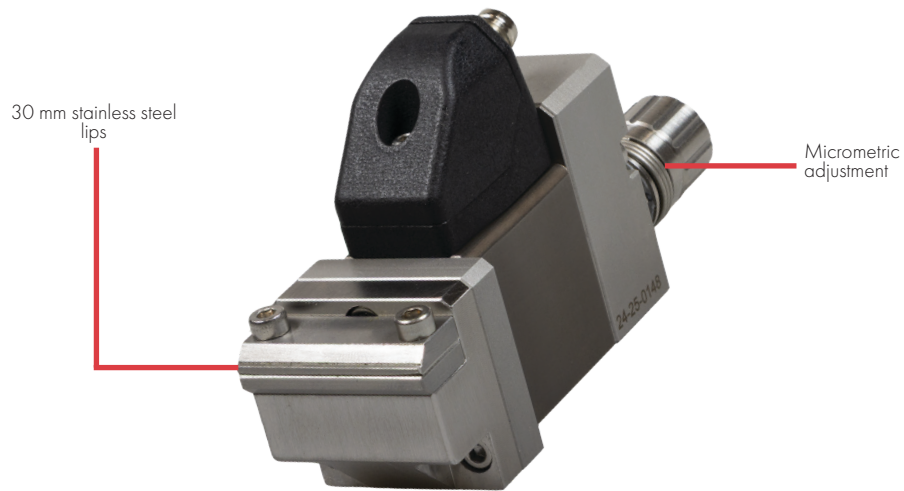

CODE

EF16CX1200 Coating valve
VH2SPL 30 mm 6 Volt

EH16CX1240 Coating valve
VH2SPL 30 mm 24 Volt





PARTS LIST ELECTROMAGNETIC VALVE VH2 SPL 30

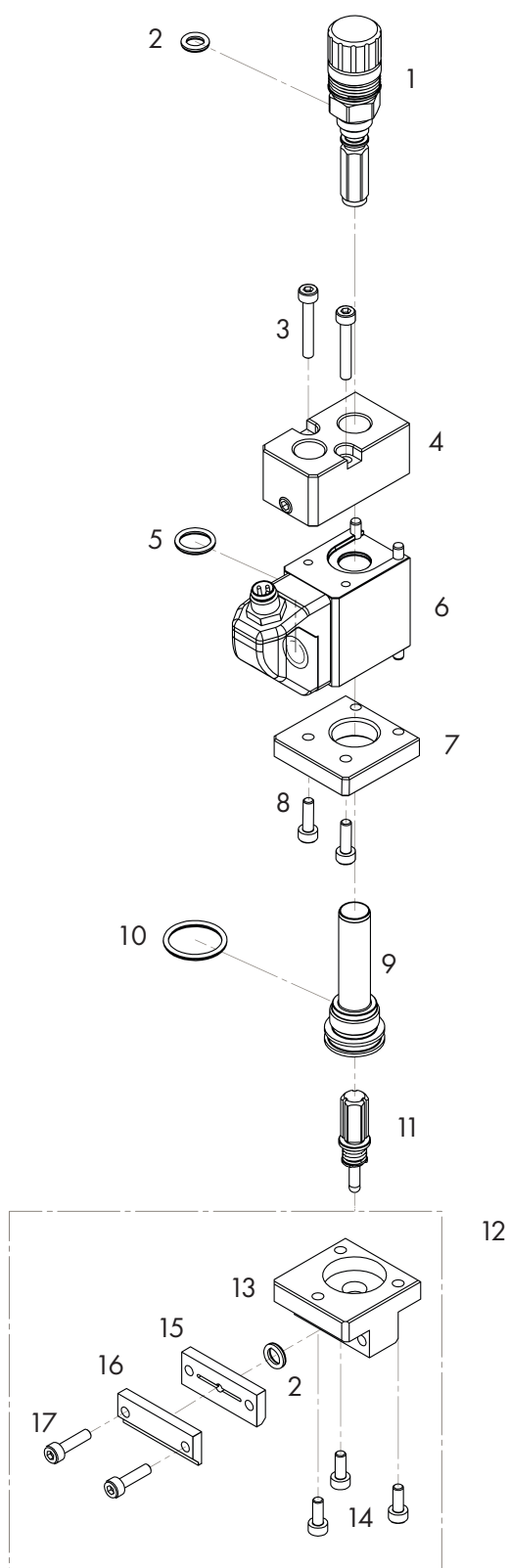



pos.	code	q.ty	description
1	B27000023	1	Micrometric adjustment
2	RNG000008E	1	O-ring ¹
3	SC00030201	2	Screw
4	BG000120	1	Rear valve body
5	RNG000011E	1	O-ring ¹
6	CL000018 CL000108	1	Core coil 6 Volt Core coil 24 Volt
7	BG000156	1	Front valve body
8	SC00030101	2	Screw
9	B27001310	1	Guide sleeve
10	RNG000015V	1	O-ring ¹
11	B27003200	1	Needle KV
12	CTH000700	1	Coating head complete
13	SRH000008	1	Coating head
14	SC00030081	3	Screw
15	CPP000895	1	Lower coating plate
16	CPP000896	1	Upper coating plate
17	SC00030121	2	Screw
	KGN000103	1	Gasket kit ¹



DIMENSION

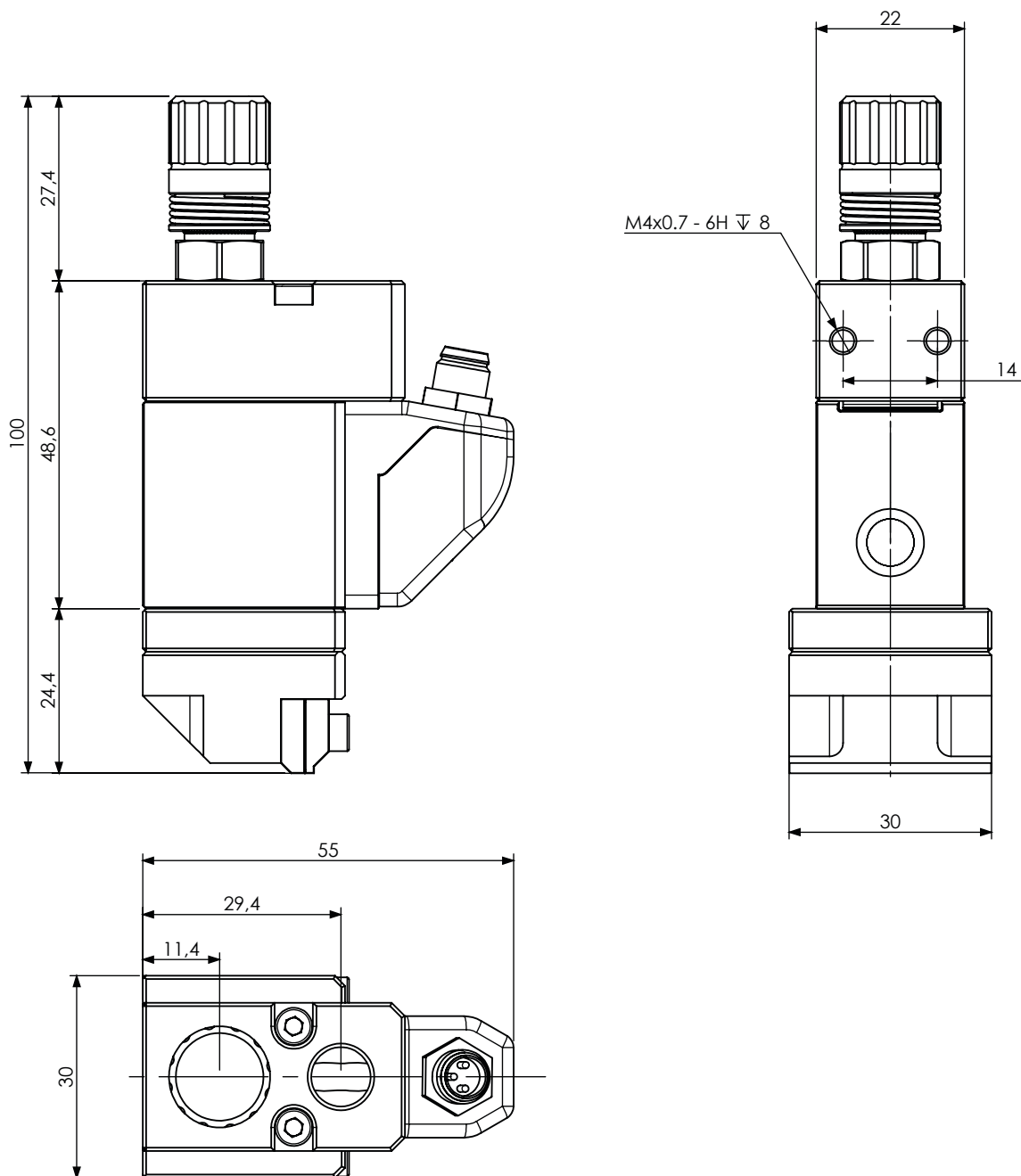



Zator
GLUING AND FLUID SOLUTIONS

DATASHEET VH2 SPL 30_V02

ZATOR SRL

Via Galvani, 11
20095 Cusano Milanino (MI)
Italy

Tel. +39 02 66403235

Fax +39 02 66403215

info@zator.it

www.zator.it

